



Roly Bolton –  
Ph. 0508 627232 – Mob. 027 492 7329  
Email. roly@masada.co.nz  
Website: www.masada.co.nz

# D5 BUILDING BOARDS (MASADA)

---

DIRECT FIXED CLADDING SYSTEM MANUAL



# FORWARD

## D5 BUILDING BOARDS – DIRECT FIXED CLADDING SYSTEM MANUAL

---

### D5

---

D5 Building Boards are manufactured by Poly Marketing Pty Limited of Tasmania, Australia and are marketed under the brand name 'Masada' in New Zealand by Polymer Products Limited. They have been used successfully in regions as diverse as the cyclone regions of Northern Australia, the cold of Southern New Zealand and the Chatham Islands.

---

### BUILDING CONTROLS

---

D5 Building Boards and accessories are classified as Type A uPVC wall cladding as prescribed in the joint Australia/New Zealand standards AS/NZS 4256 & AS/NZS 4257.

---

### EXPANSION AND CONTRACTION

---

All uPVC building boards expand and contract with temperature changes. A feature of D5 Building Boards is that they are fixed through slots to allow for this movement. The benefit of this is that the boards will remain straight (subject to the framing) when fixed in accordance with the recommendations in this manual.

---

### TRIMS

---

D5 Building Board is a very versatile material and with a complete range of fixing trims. The trims are easily cut to size and are installed in conjunction with a compatible silicon sealant as required. Thus any problems which arise in unusual situations, particularly when recladding, can be resolved.

---

### SEALANTS

---

A weather-tight building envelope is required. It is the responsibility of the designer, builder and contractor to ensure sound design principles are followed including where the sealants are used in conjunction with flashings. Care must be taken by these persons to ensure installation has been carried out correctly.

Only some silicone sealants are approved for use with the D5 Building Board (Masada) Twin-wall uPVC wall cladding system;

- FOSROC SILAFLEX MS Building Sealant
- HOLDFAST Fix All 220 LM Building Sealant

**SILAFLEX MS** is a neutral cure, non-slumping, elastomeric sealant based on a silicone - modified organic polymer that has an Appraisal Certificate [BRANZ APPRAISAL CERTIFICATE No. 311 (1995)].

**Fix All 220 LM** is also a modified polymer based sealant with similar properties and has an Appraisal Certificate [BRANZ APPRAISAL CERTIFICATE No. 419 (2001)].

The design of weather-tight joints and any detailing must be in accordance with the principles of good design such as described in the respective Appraisal Certificates and in BRANZ Bulletin No. 283. It is expected the sealants when used and maintained correctly will remain serviceable for 15 years or more in an exterior environment. This will meet the NZBC clause B2 DURABILITY requirements for Performance, B2.3.1 (b) 15 years.

# FORWARD

## D5 BUILDING BOARDS – DIRECT FIXED CLADDING SYSTEM MANUAL

---

### **PRIOR TO FIXING**

---

D5 Building Boards should be checked before installation. Any damage due to transportation should be notified immediately to the freight company responsible. The D5 Building Board is manufactured by a dynamic extrusion process and minor variations and extrusion lines are normal. However, if any board is considered unacceptable then it should be kept aside, protected, and your distributor contacted.

---

### **STORAGE**

---

D5 BUILDING BOARDS SHOULD NOT BE STORED IN DIRECT SUNLIGHT AS THE PLASTIC WRAPPING WILL CAUSE THE PACKS TO HEAT WHICH MAY CAUSE BUCKLING OR DISTORTION. PACKS SHOULD BE STORED FLAT ON A CLEAN SURFACE OR ON BEARERS AT 600MM CENTRES IN A SHADY POSITION. DO NOT LAY OTHER MATERIALS ON TOP. D5 BUILDING BOARDS ARE PACKAGED IN BUNDLES OF FOUR AND IT IS RECOMMENDED THAT TWO PEOPLE HANDLE THE BOARDS.

---

### **STACKING HEIGHT**

---

Variations in the stacking height of boards can occur during the extrusion process. The stack heights are written on the packs eg: 1018, 1021 etc. In the case the difference would be 3mm over eight boards. Your distributor always batches a house lot to the closest possible stack heights but fixers should be aware and use highest stack heights at the bottom of the wall, making sure that boards line up, particularly on internal corners. If ordering for an addition to an existing D5 Building Board house the measurements on the existing boards should be given to facilitate the best match. When nearing the end of a job the boards should be slid out of the last packs so that the wrapping is kept intact for any whole boards left over.

AT ALL TIMES INSTALLERS SHOULD BEAR IN MIND THAT THEY ARE INSTALLING A PRE-FINISHED PRODUCT. CAREFUL ATTENTION SHOULD BE PAID TO DETAILS AND CARE SHOULD BE TAKEN IN THE HANDLING OF THE PRODUCTS.

D5 Building Boards can withstand high impacts but it should not be dragged across abrasive surfaces or walked on, and care should be taken to avoid dirt or grit getting into the packs.

---

### **TEMPERATURE**

---

It is important to consider the ambient temperature during installation. Boards will expand and contract depending on temperature conditions, so expansion gaps must suit both the length of the board and the temperature on day of fixing. From coldest (say  $-5^{\circ}$ ) day to hottest (say  $35^{\circ}$ ) day, a 5.8 metre board will expand about 5-6mm each end, and a 1 metre board by around 1mm each end. Therefore if fixing on a very hot day, very little expansion gap should be allowed for. If fixing on an average day (say  $15^{\circ}$ ) then leave a gap of 3mm each end for expansion of a 5.8 metre board, on a cold day leave 6mm. If the wall is less than a board length, then measure distance and cut allowing for expansion of board as above. The shorter the board the less allowance for expansion is required.

# FORWARD

## D5 BUILDING BOARDS – DIRECT FIXED CLADDING SYSTEM MANUAL

---

### CUTTING

---

D5 Building Boards can be cut with any sharp fine toothed saw blade, standard hand saw, tenon saw or electric circular or drop saw and even a masonry type cutting disc. Other useful tools are tin snips, pliers, utility knife and putty knife. When using power saws care should be taken not to apply force too hard or quickly.

---

### CLEANING UP

---

D5 Building Boards can be easily cleaned using a mild household detergent (washing up liquid) suitably diluted in water, wash off any dirty or greasy smudges which may have occurred during the fixing. This cleaning up stage of the job is ideal to combine with a thorough check of all parts of the installation.

DO NOT USE SOLVENT BASED OR ABRASIVE CLEANERS.

---

### FIXINGS

---

D5 Building Boards may be fixed at up to 600mm maximum centres. The end of each board must always be fixed especially at every corner. Each fixing should be placed in the centre of the nailing slot and driven in till the head is just clear of the surface of the nailing strip. ALLOWANCE MUST BE MADE FOR THERMAL EXPANSION AS PER TEMPERATURE ABOVE.

TIMBER FRAMING – use minimum 9mm head, 2.8mm shank, 40mm long hot dipped galvanized steel fasteners that comply with AS 3566 for fixing through battens into timber framing

STEEL FRAMING – all steel framing is specific and the manufacturer of the framing should be consulted to ensure all fixing selected is suitable. As a guide we recommend using 9mm head, 2.8mm shank, 40mm long hot dipped galvanized steel self tapping pan head screws that comply with AS 3566.

In salt spray zones, 304 Stainless Steel plated screws are required.

---

### CHECKLIST BEFORE COMMENCING WORK

---

- D5 Building Boards shall be installed in accordance with these instructions and specific standards installation requirements (E2/AS1), using good trade practice. Workmanship during site installation, including handling and storage, is the responsibility of the installer. All fasteners for building boards and soffit lining sections, accessories, battens and building wrap must be driven into solid holding supports such as timber or steel studs.
- D5 Building Boards must be fixed to framing with studs at up to 600mm maximum centres.
- Prior to fixing the D5 Building Boards ensure that an approved building wrap and flexible flashing tape is fixed in accordance with E2/AS1. Building Wrap is to be run horizontally, upper sheets are lapped over lower sheets, is lapped not less than 75mm at horizontal joints, is lapped not less than 150mm over studs at vertical joints and is added as a second layer over head flashings.
- Ensure the frame is straight and studs are in line.

# INSTALLATION

## D5 BUILDING BOARDS – DIRECT FIXED CLADDING SYSTEM MANUAL

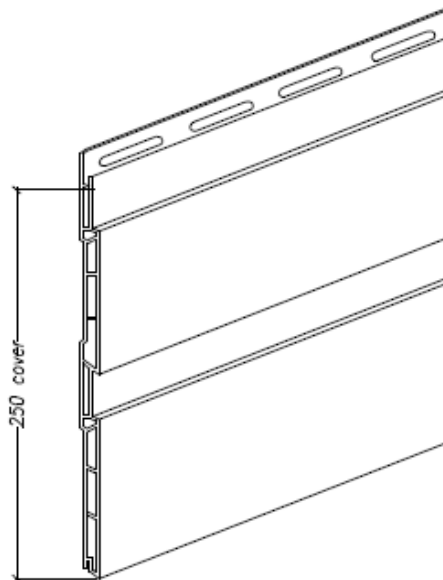
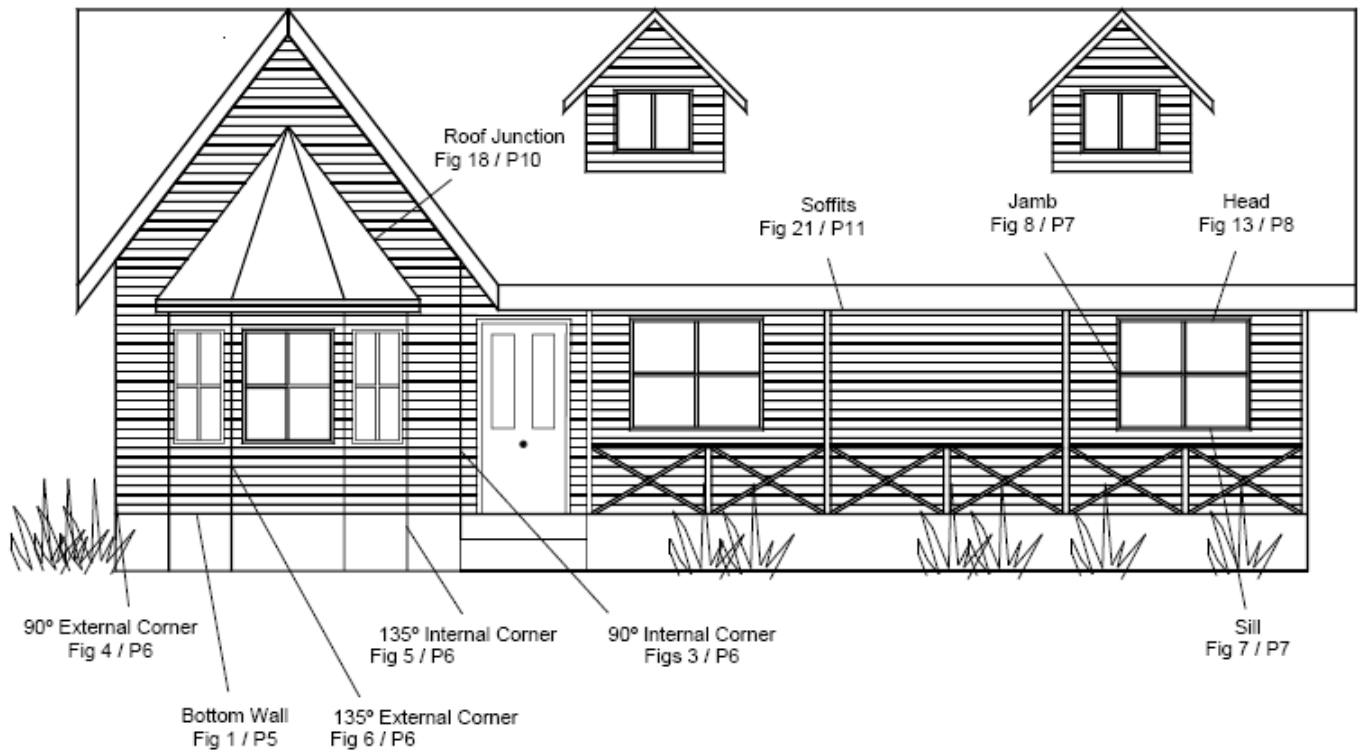

D5 Building Board Profile

# INSTALLATION

## STARTING

### STARTING

For concrete slab level, the base of the D5 Building Boards shall be:-

- (a) finish a minimum of
  - i/ 100mm above a paved surface, or
  - ii/ 175mm above an unpaved surface
- (b) overlap the concrete slab by 50mm, and
- (c) be offset horizontally by a minimum of 6mm to prevent capillary action.

For suspended timber floors, the base of the D5 Building Boards shall be:-

- (a) overlap the timber bottom plate by 50mm minimum, and
- (b) be offset horizontally by a minimum of 6mm to prevent capillary action.

Define the lowest point around building by measuring off the underside of soffit. Transfer this point to the other end of the wall by measuring down from underside of soffit. Apply chalk line between two points thus giving you a line to secure Starter. Follow the leveling procedure on all walls ensuring that the lines meet up on all corners. Commence starter 50mm from all corners. Fix starter at 200mm centres maximum in slots provided. It is normal to stay parallel with soffit and windows as these places will show any discrepancy in levels.

**FOOTNOTE:** At this stage you can either go right around house or do one wall at a time.

If a greater coverage is required then rout the rear surface of the bottom row of D5 Building Board at the desired level and engage the routed line with the starter strip as shown in Fig 2.

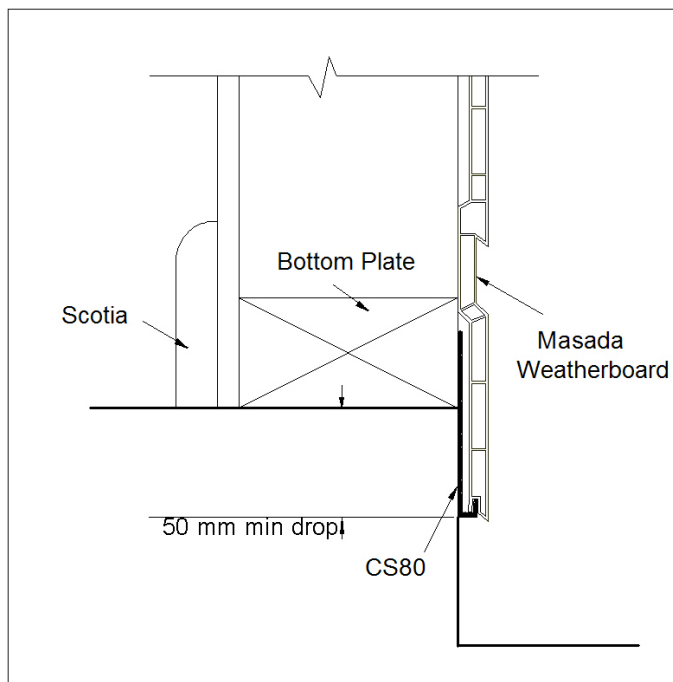

Fig 1 Bottom Wall Starter

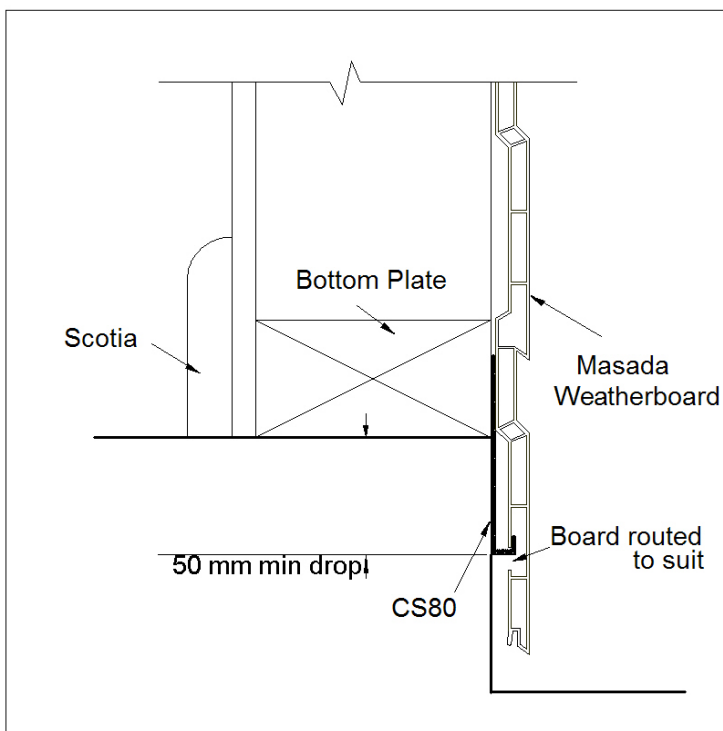

Fig 2 Half Drop Starting

# INSTALLATION

## CORNERS

### CORNERS:

Measure corners vertically to bottom edge of first board. Use appropriate accessory as detailed in diagrams below to the best situation and cut to length. Place first fixing halfway up wall and position at top of slot to prevent sliding down. All other fixings at 200mm shall be fixed in centre of slot. Fix all internal and external corners on the building. DO NOT at this stage fix corner caps.

NOTE: Where an internal corner is on a small return the CU/CA25 method is recommend, see Fig 3b.

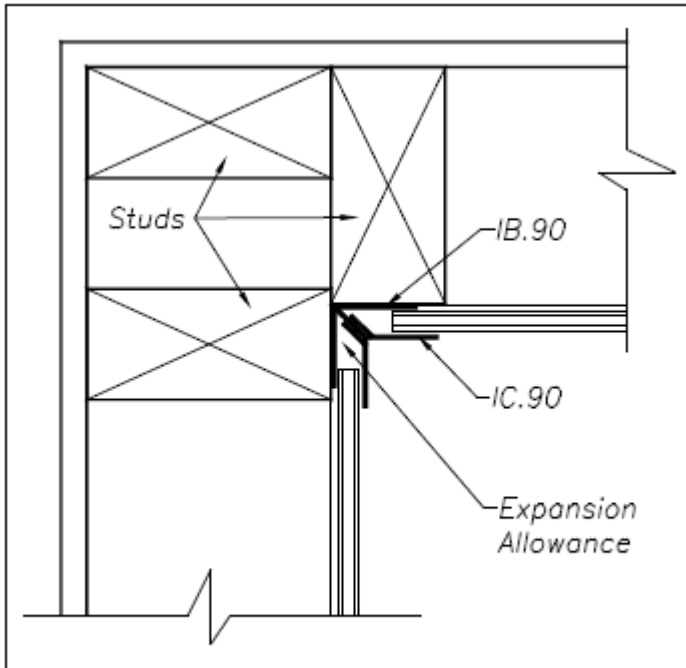

**Fig 3a 90° Internal Corner**

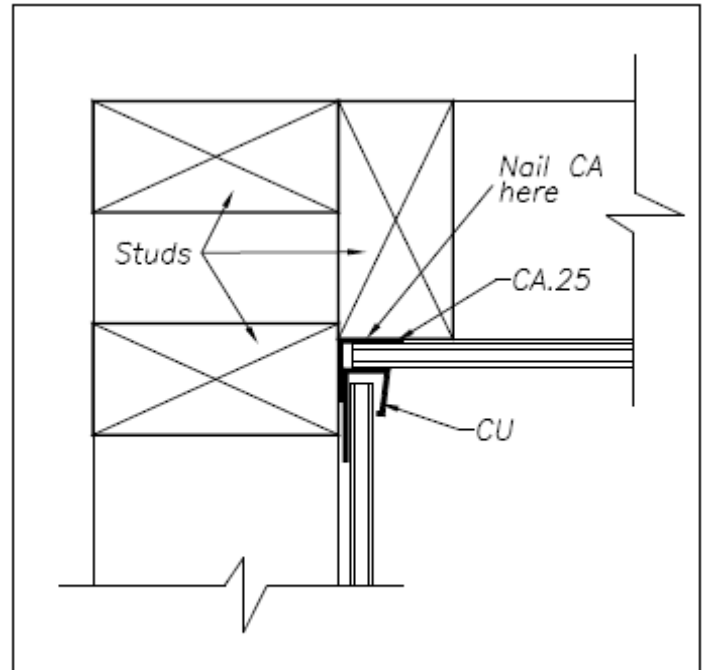

**Fig 3b Alternative Internal Corner**

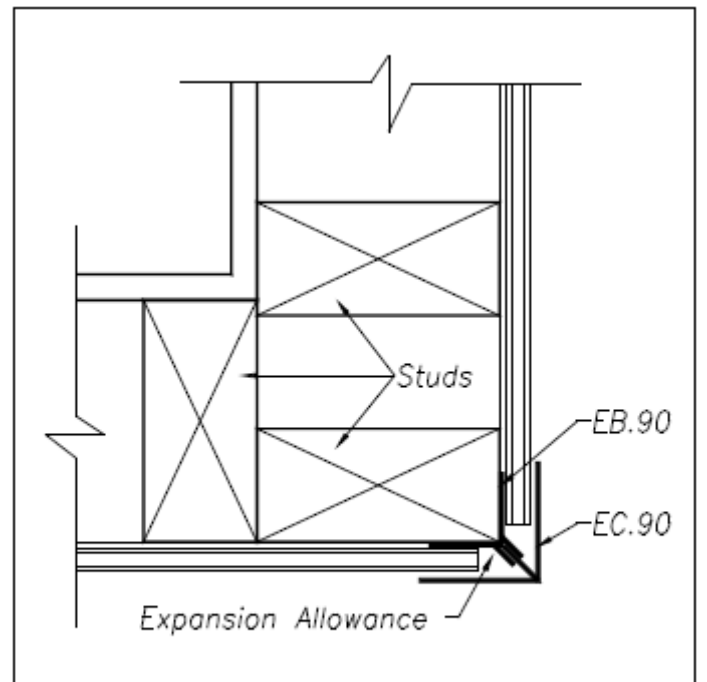

**Fig 4 90° External Corner**

# INSTALLATION

## CORNERS

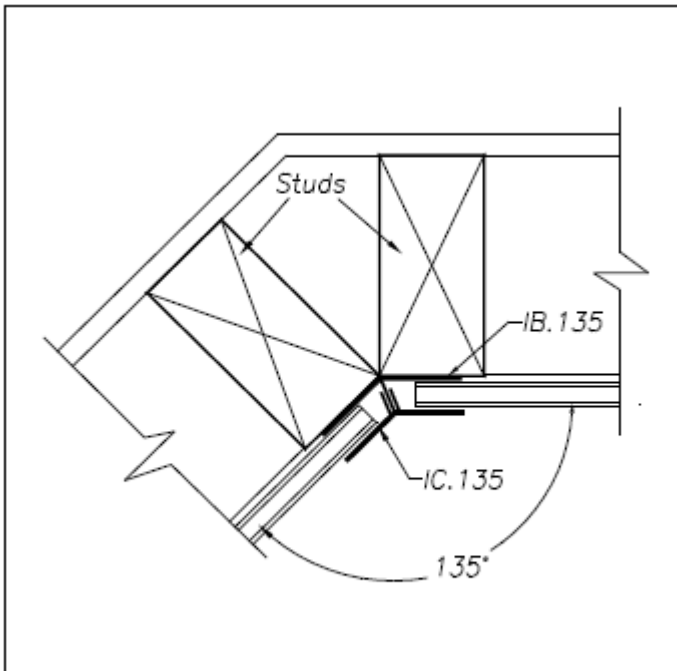

**Fig 5 135° Internal Corner**

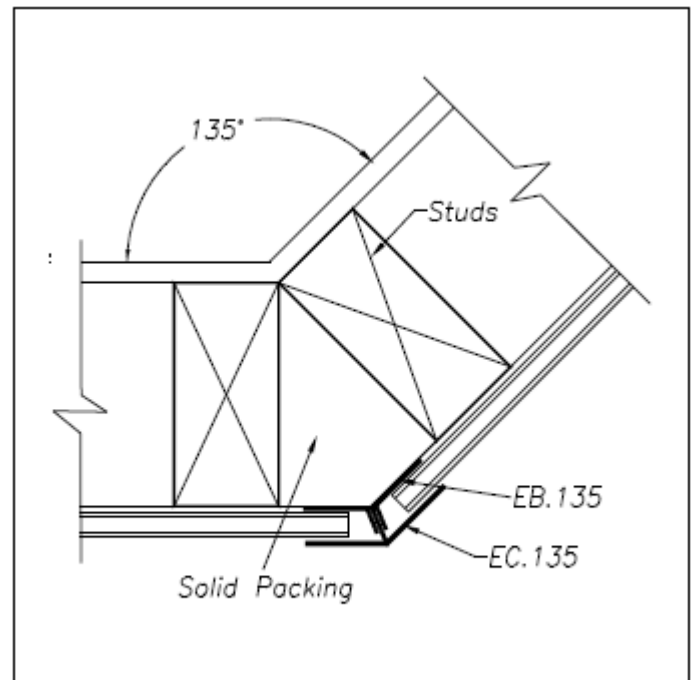

**Fig 6 135° External Corner**



# INSTALLATION

## JOINERY

### JOINERY

Joinery should be ordered with an allowance of 19mm for the D5 CU mould. Use CU Utility 'J' moulds to flash around sides of door ways and windows and base of window jambs and sills (See Fig 7 & 8).

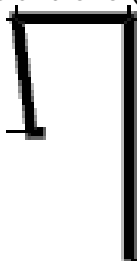

Fix at 200mm centres maximum. Aluminum head flashings are required for curved windows. When installing CU mould to window jambs the rear of the CU mould should be left longer by 50mm (see Fig 9). Windows and doors should be tacked into openings and then CU moulds lined up correctly and fixed in place.

### END CAPS

End caps should be carefully applied by the use of solvent cement into the gaps of the D5 Building Boards around windows, doors and corners. Care should be taken when using solvent cement with any excess removed immediately.

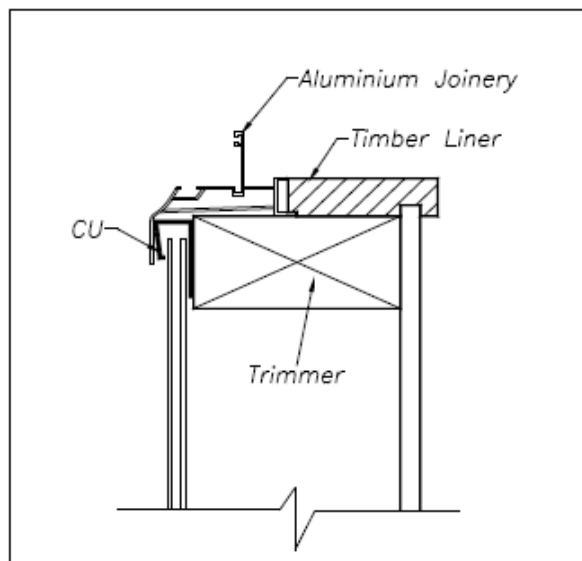

Fig 8 Jamb

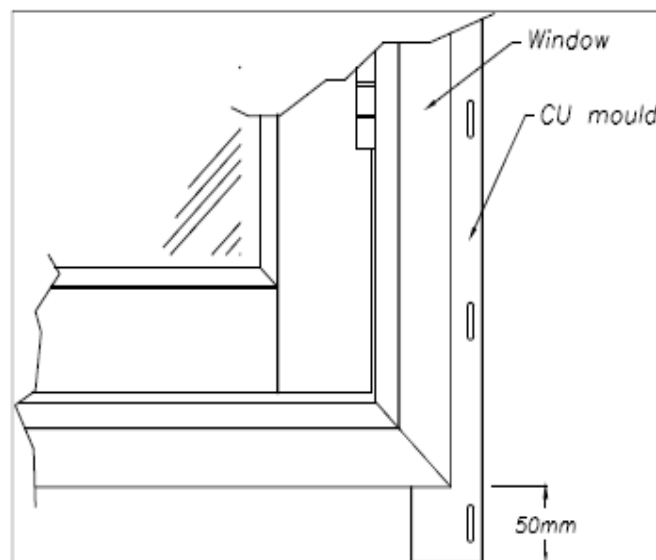

Fig 9

*Alternatively seal board to joinery with INSEAL foam sealing strip.*

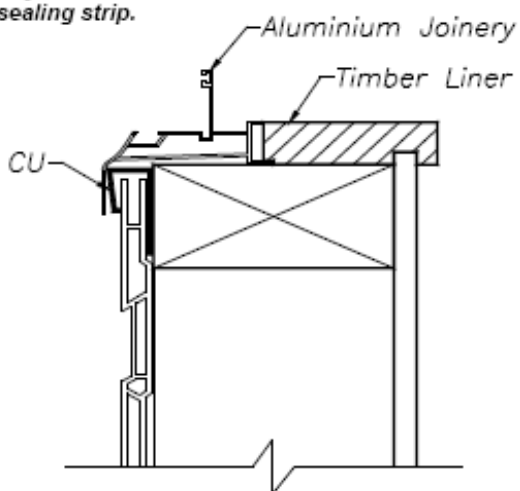

Fig 7 Sill

# INSTALLATION

## HEAD FLASHINGS

### HEAD FLASHINGS

Use WEF Window Flashing for above windows and doors. The channel at each end of the WF Extend WF moulding 35mm to 50mm each way beyond the opening dimension.

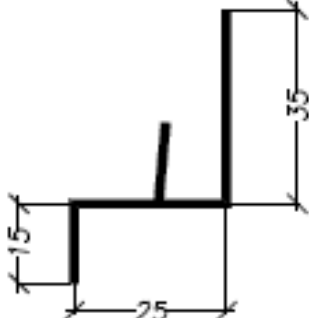

The channel at each end of the WF should then be cut to form a flap which will fold down into the CU mould ie: cut the correct distance in on both sides of the bottom of the channel and fold flap down as shown in Fig 12. If the building board meets the WF below the chamfer on the board then pack the WF moulding out 6mm, see Fig 13.

Once D5 Building Boards are in place the windows should be pulled in tight to CU moulds then fixed in place. See Fig 14.

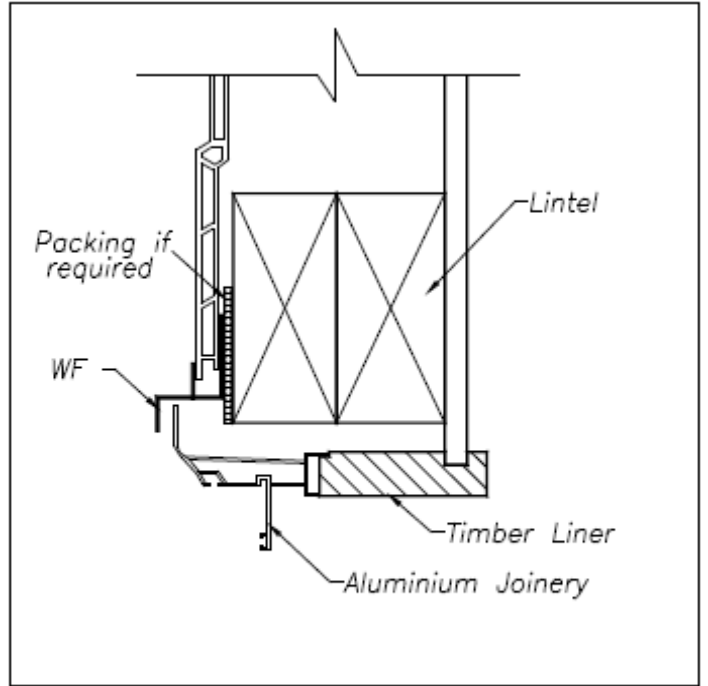

**Fig 13 Window Head**

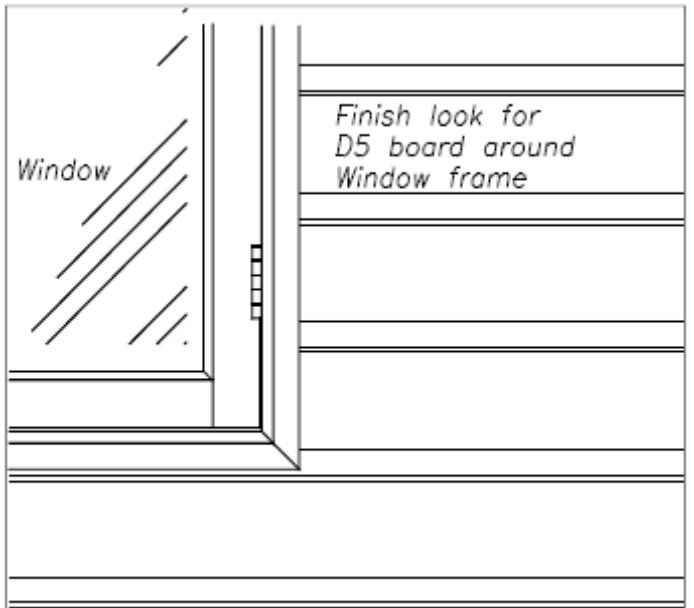

**Fig 14**

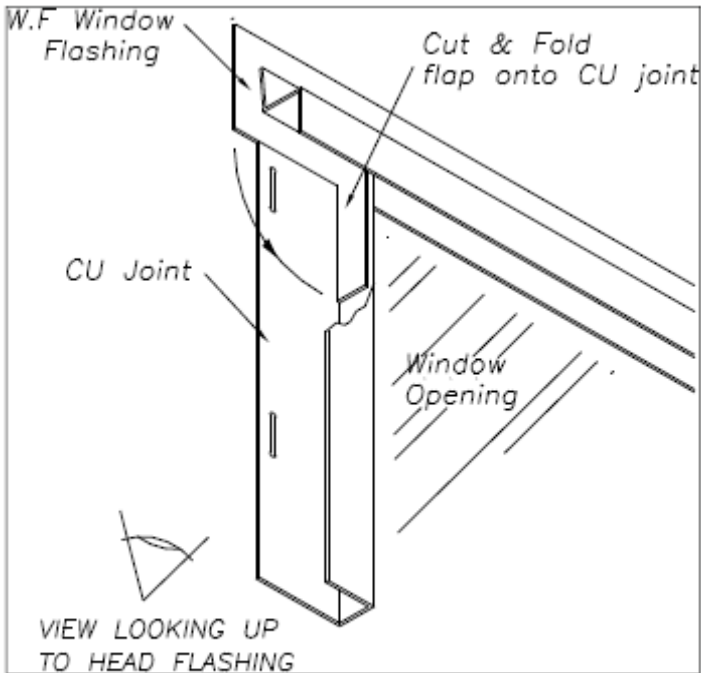

VIEW LOOKING UP  
TO HEAD FLASHING

**Fig 12 Head Flashing**

# INSTALLATION

## BUILDING BOARDS

### BUILDING BOARDS

Before starting to fix D5 Building Boards check the stack heights and temperature (see forward notes).

Start fixing boards to areas requiring long boards first for best economy. Make sure bottom groove in board is kept clear of dirt before fixing as dirt in the groove can affect stacking height.

CHECK STACKING HEIGHT PROGRESSIVELY.

Install first board into the Starter Strip. Ensure it is engaged properly with starter and all subsequent boards are engaged into lower boards properly and fix at 600mm centres maximum allowing for expansion.

DO NOT FIX HOME (see Fig 15)

When fixing a board on, begin with the middle slot and place fixing at each end of this slot. This prevents the board creeping in one direction. All other fixings should be in the middle of the slots along the length of board. When fixing short lengths of board (under 2.5m) it is acceptable to fix one end solid so that all expansion and contraction takes place towards the other end. For a short length between a window and a corner it would be best to fix the window end solid and let movement occur into the corner cap.

If off stud joiners are required fix SJD5 joiner (note that solid backing is not required behind joiner) to first board then fix next board and push into other side of joiner. Alternatively boards can be joined in a vertical line over a stud using a CB and CJ.

CAREFUL CONSIDERATION SHOULD BE GIVEN TO POSITION AND TYPE OF JOINER USED WHICH CAN GREATLY ENHANCE THE FINISHED APPEARANCE.

Some installers prefer the lines of the strip on stud joiner CJ instead of staggering the single joiners eg: a gable end could be bisected by a vertical CJ strip and CJ strips may be placed strategically under windows to blend in, or under down pipes.

### HANDY HINT

Joiner SJD5 – bending the end of the wings out slightly allows an easier lead in for the boards.

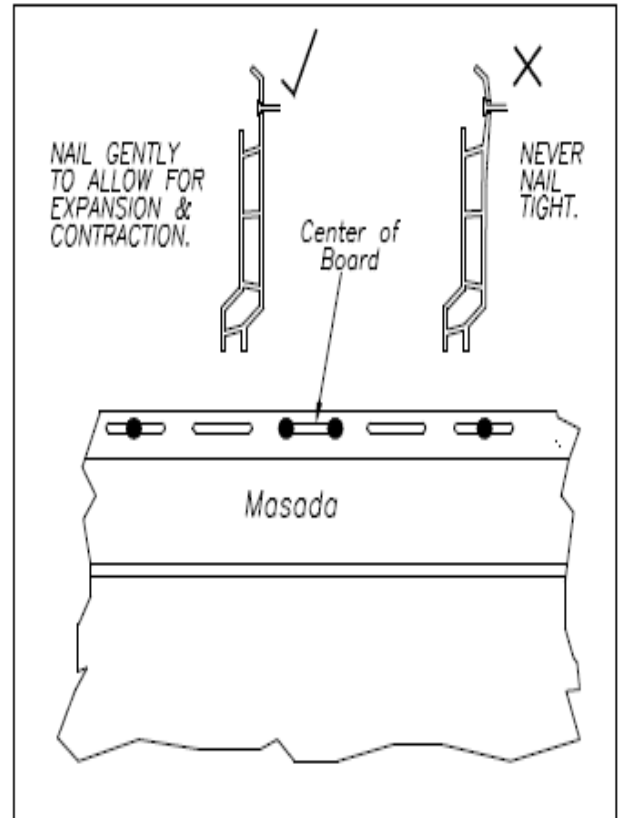

Fig 15 Fixing Details

# INSTALLATION

## WALL TRIM

### WALL TRIM

On completion of soffit fixing it is necessary to fit the CB base or CU to the wall immediately below the soffit. When using CB base continuous support is required so that the CC cap can be pressed into it. If fitting CB base ensure 3mm clearance under the soffits to provide a tight fit for CC cover against the soffit (see Fig 16a). If fitting CU mould for this application ensure that it is pressed up hard against the soffit so that no gap will appear at this point see Fig 16b. Fix at 200mm centres.

### FIXING TOP BOARD

If using CB/CC at top of wall then cut top board lengthways to finish 5mm below the centre of the CB base. Clip on CC cap to hold in place (see Fig 16a)

If using CU trim at top of wall measure from the lip of the second to top board up to the soffit and rip the last board to this measurement. The ripped board can then be pushed up into the CU trim and clipped down onto the previous board. If the last board is cut on the return then it may need to be packed out to prevent gapping. Where a D5 Building Board ends against another material eg brick, then a CU trim can be used to finish the ends.

External Corner Cover Cap goes on after CC has been installed and is carried up to underside of soffit over CC or CU.

### HANDY HINT

CB installation – clip off cuts of CB and CC together and cut off bottom half of CC to make a template to mark the correct distance to fix the CB below the soffit

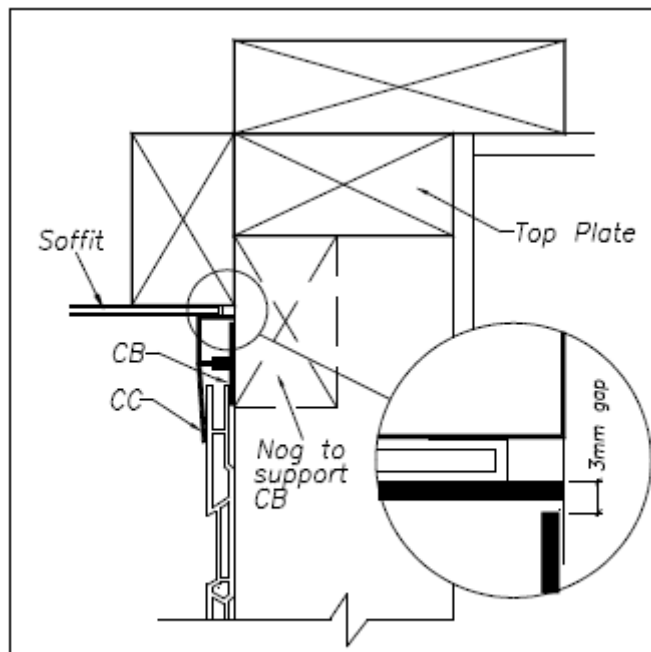

Fig 16a Top Wall—Under Eave CB/CC

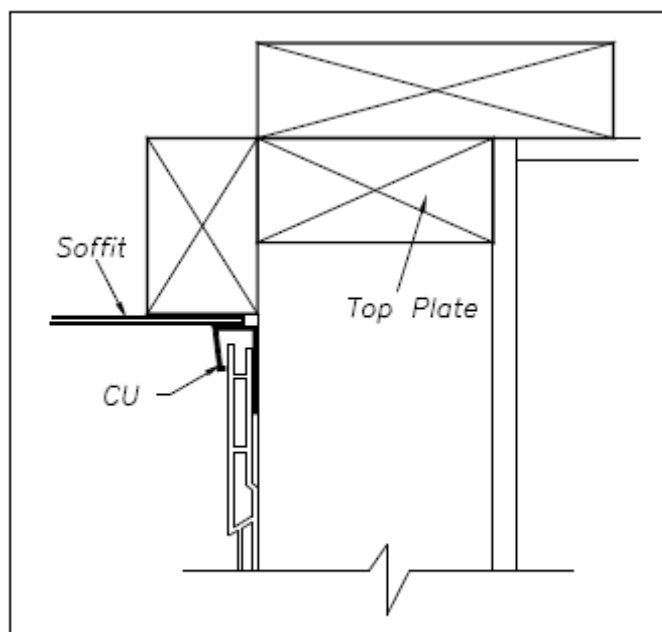

Fig 16b Alternative CU Under Eave

# INSTALLATION

## ROOF JUNCTION

### ROOF JUNCTION

Flashings must be installed to suit roofing prior to installation of D5 Building Board. Use CU as shown fixed at 200mm maximum intervals (see Fig 18 & 19)

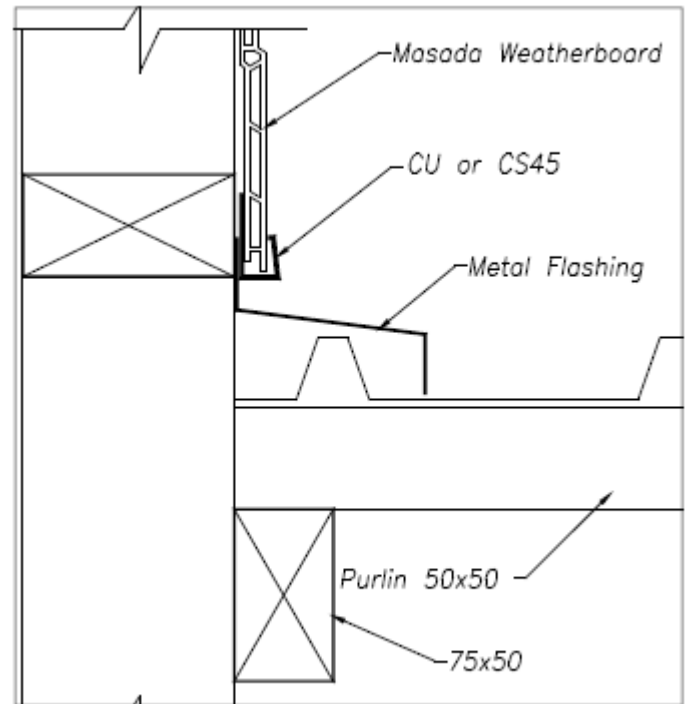

**Fig 18 Roof Flashing**

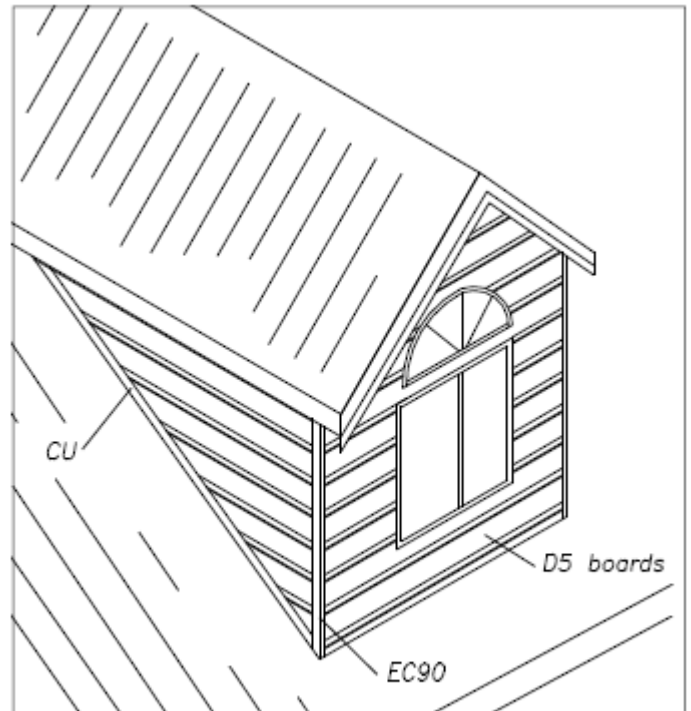

**Fig 19 Raking line over Roof**

# INSTALLATION

## SOFFIT/EAVE LINING

### SOFFITS/EAVE LINING

Soffit must be fixed before CB or CU trims are fitted to top of wall. Fixing is effected by starting from a corner point and working towards the next corner. The first board should be fitted into the fascia slot or soffit JM trim. Fixing should be effected at both ends of the nailing strip. Subsequent soffit boards are appropriately cut and inserted progressively using the integral tongue and groove facility of the soffit board product (see Figs 20a & 20b). Fixing should be attended to diligently such that both ends of each board are fixed and that no span exceeds 400mm. If necessary install a batten as required to ensure span does not exceed 400mm (Fig 21). Accommodation for expansion/contraction should be allowed as for building board installation.

**DO NOT FIX TIGHT.**

Ensure that the tongue and groove is correctly engaged. If having difficulty engaging, this could indicate fixing too tight (see Fig 22).

NB: The soffit boards are designed to run from the wall to the fascia ie; on a 600mm soffit the boards are cut to 600mm lengths and fitted across the soffit. A soffit joining strip is used at corners when the direction of the soffit changes. A soffit J mould is available for use in situations when there is no groove for the ends of the boards, eg. Cladding over an existing soffit or finishing against a beam.

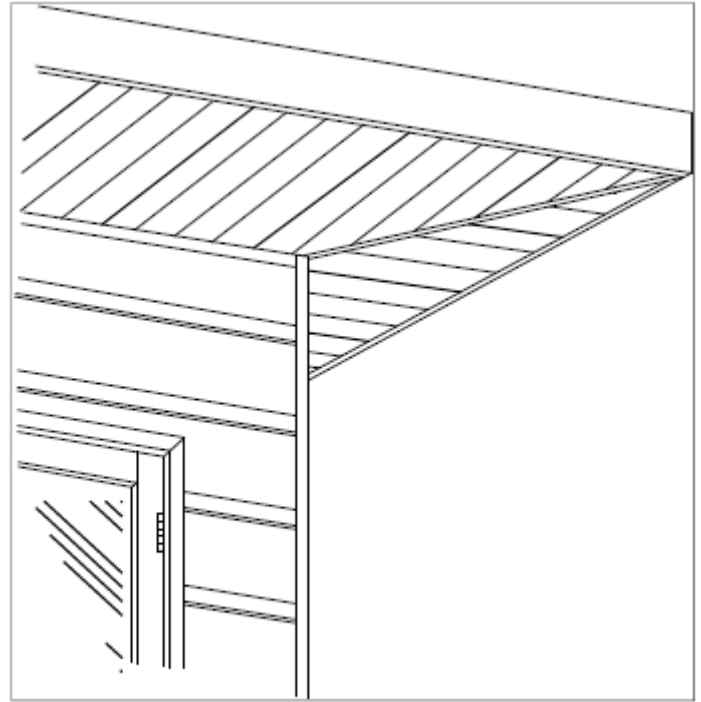

**Fig 20a Soffit Detail**

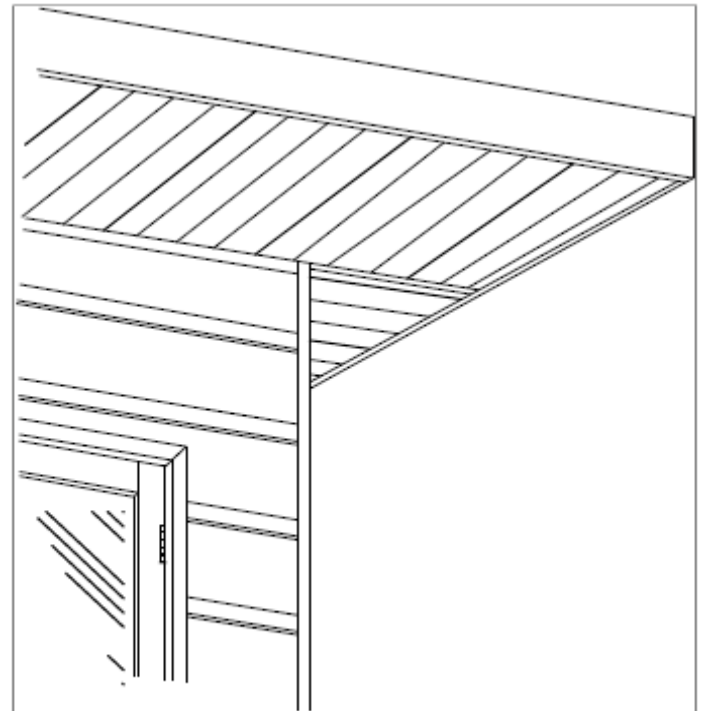

**Fig 20b Alternative Soffit**

# INSTALLATION

## SOFFIT/EAVE LINING

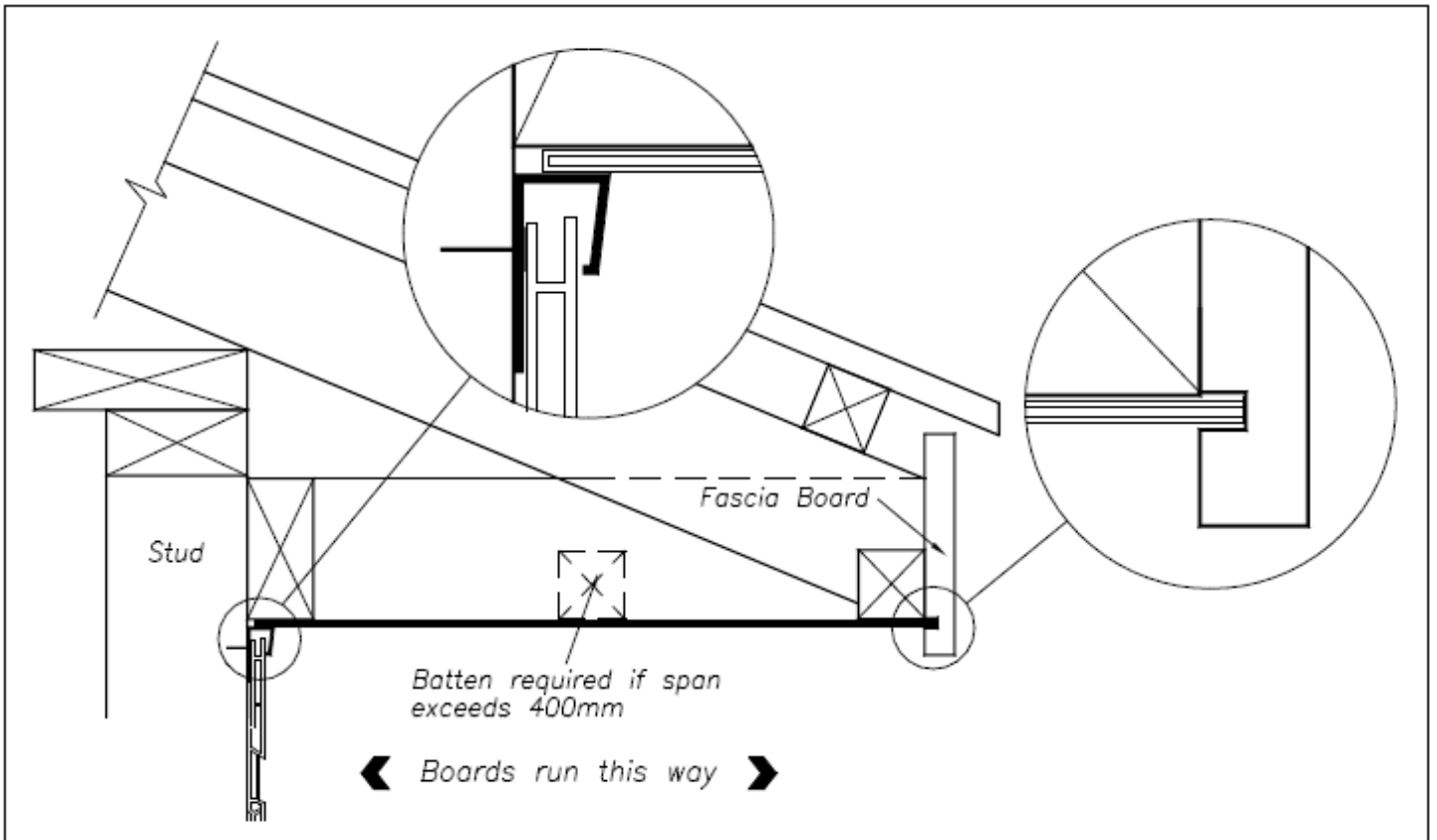

Fig 21 Soffit Detail

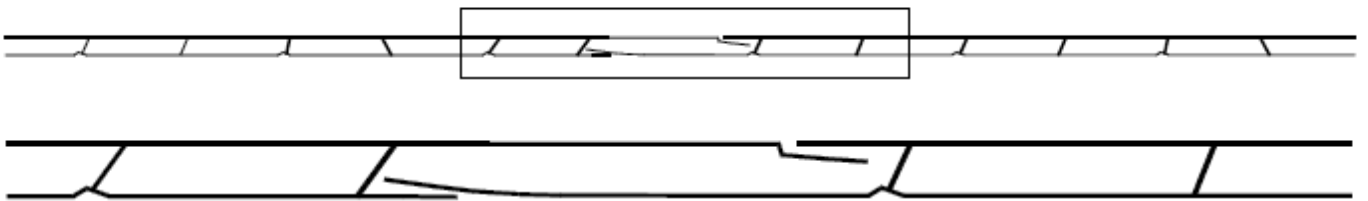
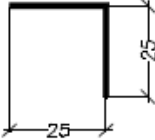

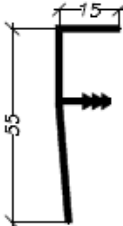

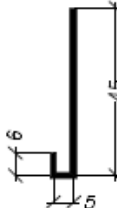
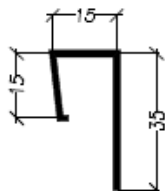
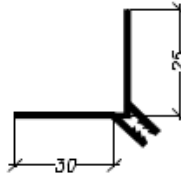
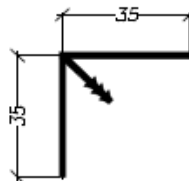

Fig 22 Soffit Assembly

# TRIM ACCESSORIES

CA	<p>CA16 16mm Angle (used for sealing the end of the board for weatherproofing at windows).</p> <p>CA19 19mm Angle (used as utility angle where needed)</p> <p>CA25 25mm Angle (used with CU to make up internal corner)</p> <p>CA50 50mm Angle (used as utility angle where needed)</p>	<p>3.70 metres</p> <p>3.70 metres</p> <p>3.70 metres</p> <p>3.70 metres</p>	
CB	Common Base (used as base for Architrave Cap (CC) and for Strip Joiner (CJ). (on stud joiner)	3.70 metres	
CC	Architrave Cap (used to finish at top of exterior wall).	3.70 metres	
CJ	Joining Strip (used to conceal joins in boards) (on stud joiner)	3.70 metres	
CS	<p>Starter Base (used for securing first board).</p> <p>Available with 45mm back (CS45) to allow first board to drop down below the bottom plate.</p>	3.70 metres	
CU	J Mould or utility channel (used to finish ends of boards into, eg around windows, meter boxes etc. Can be used in combination with CA25 for internal corners and to finish at the top of walls as alternative to CC).	3.70 metres	
EB 90	90° External Base (used for fixing external corner finishing mould at 90°)	3.70 metres	
IB 90	90° Internal Base (for fixing internal finishing mould at 90°)	3.70 metres	

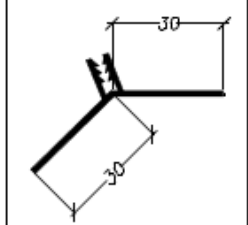
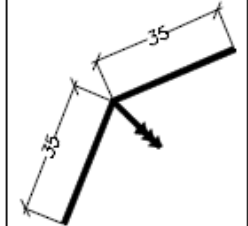
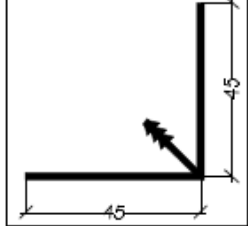
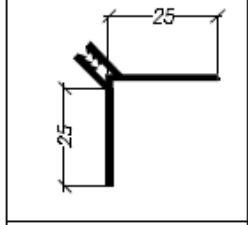
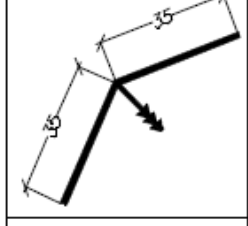
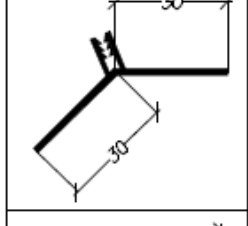
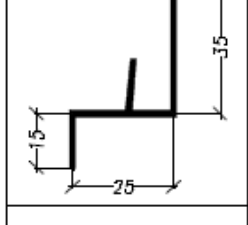
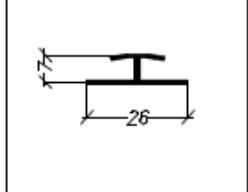

# TRIM ACCESSORIES

EB 135	135° External Base (used for fixing external corner finishing mould at 135°)	3.70 metres	
IB 135	135° Internal Base (for fixing internal finishing mould at 135°)	3.70 metres	
EC 90	90° External Cap (used for finishing external corners at 90°)	3.70 metres 5.80 metres	
IC 90	90° Internal Cap (used for finishing internal corners at 90°)	3.70 metres 5.80 metres	
EC 135	135° External Cap (used for finishing external corners at 135°)	3.70 metres	
IC 135	135° Internal Cap (used for finishing internal corners at 135°)	3.7 metres	
WF	Window Flashing (used to finish above windows and doors)	3.70 metres	
JN	Soffit Joiner (used at corners to cover soffit mitres)	3.70 metres	

# TRIM ACCESSORIES

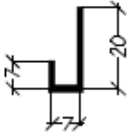
JM	Soffit J mould (used to secure soffit at fascia when a beam rather than a grooved fascia board occurs)	3.70 metres	
----	--	-------------	---

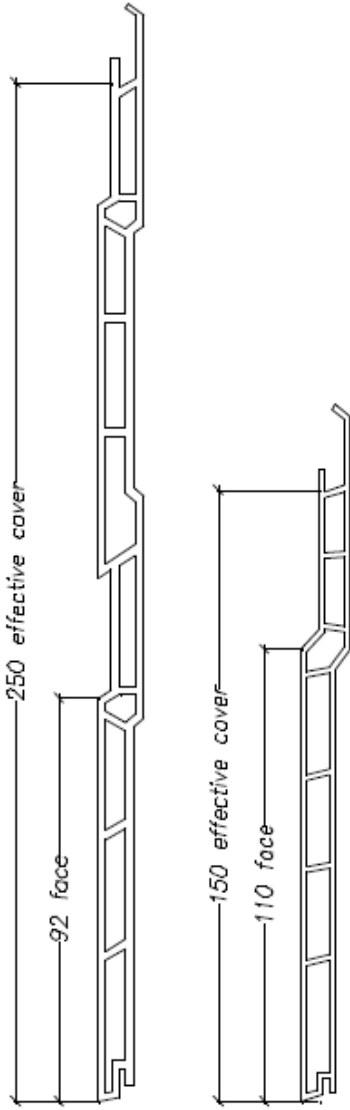

D5 & IP:  
250mm & 150mm  
cover boards

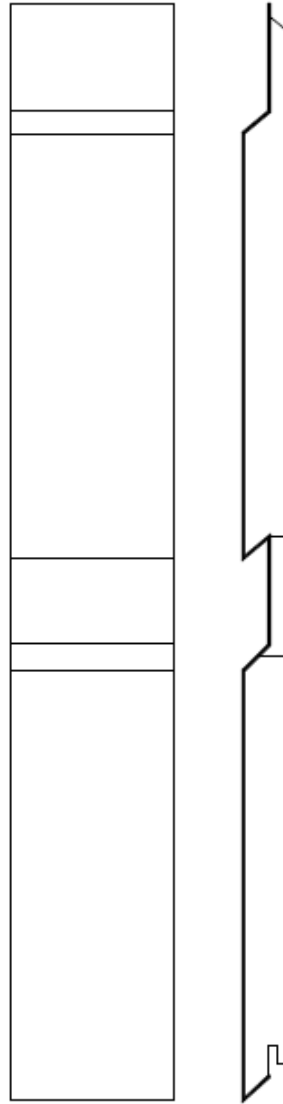

SJD5  
Single Joiner to join  
individual D5 boards  
(off stud joiner)

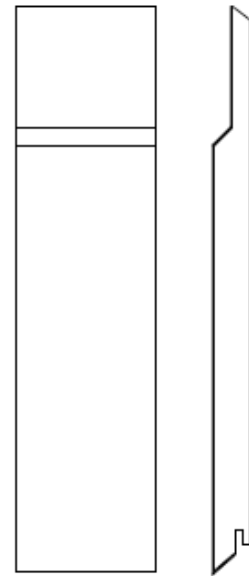

SJ150  
Single Joiner to join  
individual IP boards  
(off stud joiner)

CS	Starter Base (used for securing first board). Available with 80mm back (CS80) to accommodate the minimum 50mm drop.	3.70 metres	
----	---	-------------	---

# GENERAL INFORMATION

---

## DESIGN INFORMATION

---

D5 Building Boards and soffits provide a lightweight, horizontal external walling and soffit lining system with secret fixings. The system requires no finishing and very little maintenance apart from regular washing down. The product is intended to be used on timber or steel frame buildings.

---

## TECHNICAL SPECIFICATIONS

---

D5 Building Boards and soffits consist of interlocking hollow sections of building boards and soffit lining and a range of accessories (construction trims and flashings), which are all manufactured from 100% recyclable Impact Modified, Ultra Violet Stabilized unplasticised polyvinyl chloride (uPVC). The D5 Building Boards, soffit lining sections and accessories all have formed slots punched at regular intervals. The D5 Building Board sections have a flat chamfered weatherboard profile. The sections are supplied with a double 125mm wide weatherboard profile (D5). The hollow sections are formed from twin walls nominally 1.3mm thick which are reinforced with a web of longitudinal ribs 1mm thick running between them. The hollow soffit lining sections also have a flat twin-wall profile with shallow longitudinal surface grooves. The walls, which are approximately 1mm thick are also reinforced by eight 1mm thick longitudinal ribs. The D5 Building Boards and soffit lining sections have the following nominal characteristics.

SECTION	D5	SOFFIT
Length	5800mm	3700mm
Cover Width	250mm	203mm
Cross Section Thickness	8.6mm	5mm
Weight	4.50kg/m <sup>2</sup>	0.77kg/m <sup>2</sup>
Coverage per Board	1.45m <sup>2</sup>	0.77m <sup>2</sup>

---

## MAINTENANCE

---

The product should be regularly hosed down or cleaned with mild soapy water, especially in areas where industrial pollutants occur. Surface marks may be removed with a wet cloth and non-abrasive cleaner. Petroleum based solvents should not be used for cleaning.

---

## WARRANTY

---

Poly Marketing Pty Limited guarantees D5 Building Boards and soffit products to be free from defects resulting from faulty manufacture or materials for 15 years. Full warranty wording is available from your distributor.

# GENERAL INFORMATION

## FIRE

D5 Building Boards are suitable for domestic and commercial use where there are no specific fire requirements. The product is not easily ignited, but when exposed to a flame it will soften and burn slowly. If the flame source is removed, the burning rapidly self-extinguishes. Exposure of the product to a flame or heated surface should be avoided at all times.

Table 9.1 Ignition Temperatures for Various Materials (ASTM 1929)

	Flash-Ignition (°C)	Self-Ignition (°C)
PTFE (Teflon)	560	580
Polyamide 6	420	450
ABS	390	480
Rigid PVC	390	450
Polystyrene	350	490
PMMA	300	430
Polyurethane-Rigid Foam	310	415
Polyethylene	340	350
Polypropylene	320	350
Pinewood	240	260
Paper	230	230
Cellulose Nitrate	130	130
Flexible PVC (Insulation)	330	385
Flexible PVC (FRLA*)	400	410

\*FRLA = Fire resistant, low acid emission

Table 9.5 Smoke Emission Measurements in the US-NBS Smoke Chamber (BS6401 conditions)

Material	Thickness (mm)	Maximum Specific Optical Density (DM) Non Flaming	Flaming
PLASTICS			
UPVC	3	400	580
Polyethylene	3	590	83
FR Polyethylene	3	790	780
Polypropylene	3	550	162
FR Polypropylene	3	820	600
Polystyrene	3	476	960
PMMA	3	63	117
Plasticised PVC	0.75	430	650
OTHER MATERIALS			
Hardboard	3	580	74
Pine	6	551	132
Plywood	6	432	64
Chipboard	19	620	405
Oak	19	581	243
Plasterboard	12	77	83
Wool Carpet	6	388	217
Natural Rubber (Black)	2	721	762

*Edgerley P G and Pettet K "The Effect of Pyrolysis and Combustion Temperatures on Smoke Density Fire and Materials" Vol 2 No 1 pp 11-17 1978.*

# GENERAL INFORMATION

Rigid PVC has an oxygen index of 45-50, compared to 21-22 for wood and 17-18 for most thermoplastics. Oxygen index values above 27 can easily be attained with flexible PVC. The significance of this is that most rigid and flexible PVC will not burn alone without the application of heat from another source. Oxygen index values at room temperatures for various materials are listed in Table 9.2<sup>4</sup>. Some highly plasticised PVC formulations, such as those used in shower curtains, may sustain combustion alone.

Table 9.2 Oxygen Indices for Various Plastics

Polystyrene Foam	15
Polyurethane Foam	15
Polyacetal	15
Plexiglas (PMMA)	17
Polyethylene	17
Polypropylene	17
Polystyrene	17
ABS	18
SAN	19
Epoxy Resins	19
Polyester Resins	19
Polyamide	22
Polycarbonate	24
PPO	29
Polysulfone	30
Silicone	30
Phenolic Resin	35
Polyamide	36
Rigid PVC	50
Flexible PVC	21-36
PVDC (Saran)	60
PTFE (Teflon)	95
Wood	21-22

*"Flammability Handbook of Plastics". C J Hilado. 4<sup>th</sup> edn. Technomic. 1990*

---

## DURABILITY

---

D5 Building Boards will not rot or corrode and are impervious to moisture and from attack by vermin or termites. Over time there will be some fading of colours and chalking. This will not affect the long term durability nor weather protection, the chalking can be removed by periodic washing with warm soapy water.

# GENERAL INFORMATION

---

## AVAILABLE COLOURS

---

### COLOUR CODING

All Items are colour coded

eg. EC90	SA	Silver Ash
	GG	Ghost Gum
	GN	Mist Green
	LE	Lace
	IY	Ivory
	WE	White

Bases which will not be seen when installed  
can be any colour.



Roly Bolton –  
Ph. 0508 627232 – Mob. 027 492 7329  
Email. [roly@masada.co.nz](mailto:roly@masada.co.nz)  
Website: [www.masada.co.nz](http://www.masada.co.nz)